

# SYSTEM 50

Advanced hydraulic control for cruising and racing yachts from 35' to 70'

INSTALLATION AND OPERATING INSTRUCTIONS INSIDE

The introduction of *SYSTEM 50* represents the culmination of an ergonomic and mechanical redesign program, focused on the changing needs of modern yachts.

Ergonomically designed, *SYSTEM 50* positions the gauge, release valve and selector knob in-line, for quick and easy control. The pump is centered and low for improved mechanical advantage and less physical effort.

Mechanical improvements include a selector knob that 'clicks' into place. Function selection can be felt through the knob, an important feature at night or when the crew can't easily see the panel.

A larger cleaner gauge makes reading the pressure easier and safer. Although there is a pressure relief valve to protect the boat from over-zealous crew members, it is important to read the pressure level quickly and accurately.

*SYSTEM 50* allows for a two-speed auto-shift pump to be fitted as an option. The auto-shift pump triples the oil flow rate at low pressure for quick take-up and then shifts automatically to a slower speed when the pressure builds to a preset level.

High flow valves and ports allow panels to be easily interfaced with a hydraulic winch power pack. Oil flow supplied from the power pack is accurately controlled through the *SYSTEM 50* panel. Fine tuning at high pressure can then be completed with the hand pump.

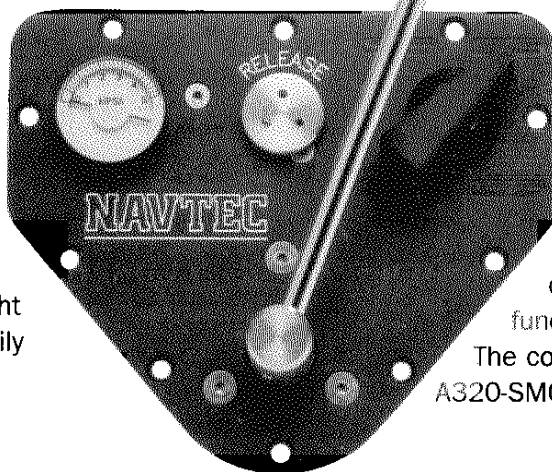

The single function panel can be converted to the multi-function panel at a later date.

The conversion part number is A320-SMC-01.

## SYSTEM 50

replaces **SYSTEM V**, which has been the industry standard for over a decade!

### BENEFITS INCLUDE:

1. Ergonomic design.
2. Increased speed for faster response.
3. Larger, easy to read gauge.
4. Available with two-speed auto-shift pump.
5. Easily interfaced with winch powerpacks: Lewmar Commander & Harken Hydro.

# NAVTEC®

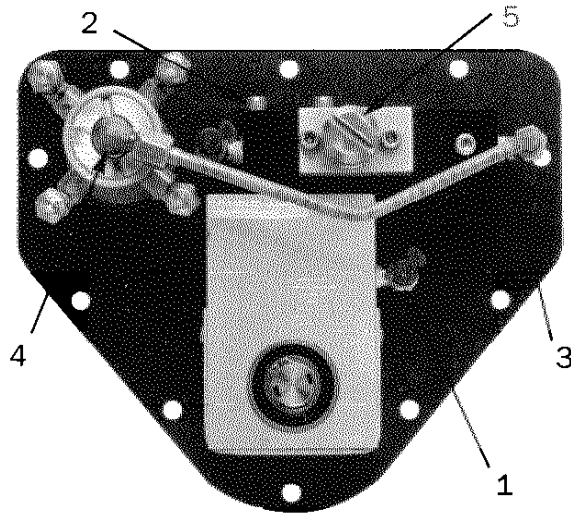
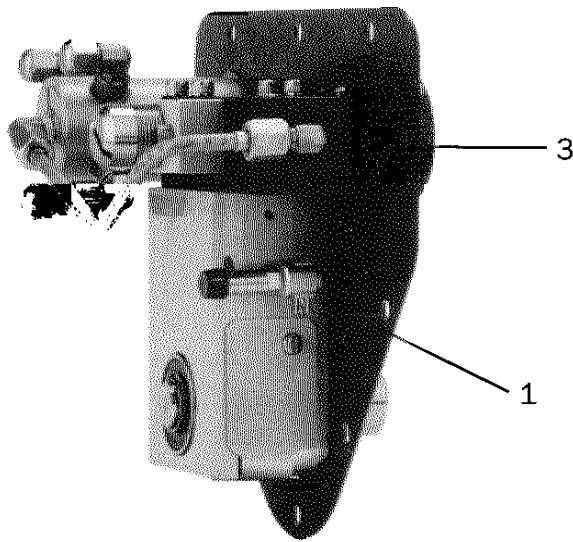

## INSTALLATION

Locate the panel position keeping in mind normal position of crew members while pumping. Use a high quality marine sealant between panel and bulkhead to prevent leaks.

Mount the separate reservoir with the hose fittings at the bottom. Be sure to leave room above the removable cap at the top of the reservoir for filling. See Table II for reservoir capacity and dimensions. If possible, the bottom of the reservoir should be above the pump as pump suction will be more positive, but this is not essential for satisfactory operation.

Place the reservoir as close to the pump as possible to minimize the effect of pitch and heel.

## PLUMBING

Connect either hose barb at the bottom of the reservoir with the pump intake hose barb (#1), using the low pressure hose supplied. Be sure there is a plastic oil filter in this line.

Connect the other hose barb on the bottom of the reservoir with hose barb (#2) on the back of the panel, using a second low pressure hose.

A single high pressure reinforced hose or stainless steel tube (rated for at least 5,000 psi) must be run from the valve on the central panel to each operating cylinder. High pressure hose, cylinders and boom vangs are available from your Navtec distributor.

- If the panel is single function, the hose or tube runs from fitting (#3).
- If multiple function, the hose runs from 1 of 4 ports on 4-way selector valve (#4).
- For push-pull cylinders, when a 4-way valve is used (this is different than the 4-way selector valve), consult your Navtec distributor or Navtec Inc. for plumbing instructions.

## OIL & FILTER

Use #10 hydraulic oil or #10 non-detergent motor oil (detergents cause foaming). Never use brake fluid because it will attack the seals. Oil should be checked periodically for cleanliness.

Any particulate matter in the oil will decrease the life of the moving parts and may also cause malfunctions.

The oil filter should be changed if there is any indication of pump skipping due to oil starvation.

TABLE I  
SYSTEM 50 SPECIFICATIONS<sup>1</sup>

DESCRIPTION	PART#	MAX DIM.	DEPTH		
			IN.	MM	
Single Function	A320-SF-01	10 x 8.5	254 x 216	4.25	108
Multi-Function <sup>2</sup>	A320-MF-01	10 x 8.5	254 x 216	4.50	115
SF w/2 speed A/S pump <sup>3</sup>	A320-SF-02	10 x 8.5	254 x 216	6.00	153
MF w/2 speed A/S pump	A320-MF-02	10 x 8.5	254 x 216	6.00	153
Multi-Function w/4 way valve <sup>4</sup>	A320-MF4-01	10 x 8.5	254 x 216	4.50	115
Single to Multi Conversion Kit	A320-SMC-01			4.50	115

1. System includes pump, valves, reservoir, filter, hose and handle.

2. Can be used as a 1, 2, 3, or 4 function panel.

3. Two-speed Auto-Shift pump has 300% greater low pressure flow rate of oil.

4. The 4 way valve is to control push-pull cylinders.

• Stainless Steel face plates can be ordered by adding an 'S' to the end of the part number ie: A320-MF01S.

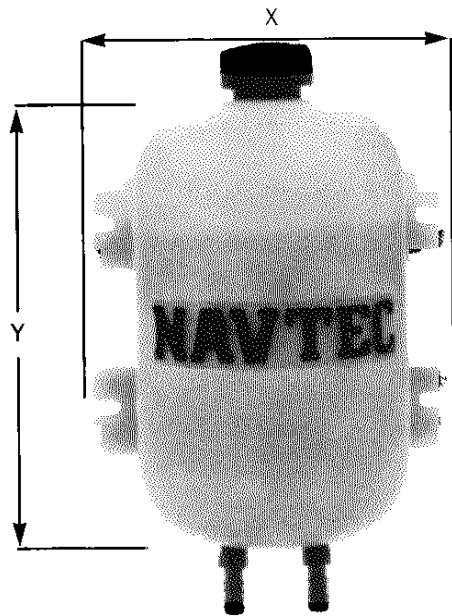

TABLE II

RESERVOIR CAPACITY & DIMENSIONS

SIZE	USABLE VOL.		X		Y		DEPTH	
	(in <sup>3</sup> )	(cm <sup>3</sup> )	(in)	(mm)	(in)	(mm)	(in)	(mm)
1 Qt.	60	983	6.88	174.8	8.00	203.2	4.88	124.0
2 Qt.	120	1967	7.75	196.9	10.88	276.4	5.75	146.1

## CYLINDERS

Standard Navtec cylinders are equipped with an air-pressure return. This return is pressurized through the 'tire' valve at the clevis end of the cylinder. A bicycle pump or service station air hose can be used to charge the return up to 100 psi. The air pressure should be adjusted to give the desired rate of return.

### WARNING:

Once charged do not attempt to disassemble the cylinder. This should be done only by an authorized Navtec Hydraulic Service center or Navtec Inc.

## BLEEDING THE SYSTEM

After installing the panel, cylinders and plumbing, oil should be added to the reservoir and the system bled of all air. Each cylinder and line must be bled separately.

- Step 1.** Open release valve fully. If system is multifunction, select function to be bled first.
- Step 2.** With hose attached to cylinder, extend cylinder fully. If there is air pressure in lower chamber the cylinder will extend automatically.

- Step 3.** Disconnect hose at cylinder. Note: always disconnect slowly to allow remaining pressure to decrease slowly. Be prepared for possible oil drips.
- Step 4.** Close release valve and pump, holding the hose end in a can to collect oil. When oil is bubble-free, reconnect hose to cylinder.
- Step 5.** Pump cylinder all the way down (with cylinder detached from rigging). Then open release valve and allow cylinder to return fully.
- Step 6.** Repeat above procedure for each cylinder and line.

## RELIEF VALVE ADJUSTMENT

The relief valve (#5) is set at the factory to approximately 4000 psi. Adjustment is provided by the 1" (25mm) round threaded cap in the aluminum valve block at the back of the panel. Maximum relief setting is 5000 psi. Turning the cap counter-clockwise will lower the setting. Clockwise will raise it. The adjustment is about 1000 psi per complete turn. To determine the setting without tensioning the rig, disconnect any cylinder from the rigging and pump that cylinder until it bottoms and the relief valve lifts, which will be evident when continuous pumping fails to raise the gauge pressure. The maximum pressure observed is the relief valve setting.

## OPERATING INSTRUCTIONS

### SINGLE FUNCTION SYSTEM (WITHOUT SELECTOR VALVE)

To increase tension in the cylinder, make sure that the release valve is closed. Do not over tighten. Doing so will shorten the life of the valve. Now pump. The valve body has a special zero-leakage check valve so no manual locking valve is necessary. To reduce tension, open the release valve. Remember, *it is not necessary to turn very hard to close the valve.*

### MULTI-FUNCTION SYSTEM (WITH SELECTOR VALVE)

This system operates the same way as the single function system (see above), except that the selector valve must be positioned before pumping or releasing tension. To position, turn the selector valve handle toward the valve port (at rear of valve) to which the appropriate hose is attached. Function labels are available from Navtec at no charge.

# GAUGE

The Navtec gauge has a double ended needle so that two scales can be used. The top scale which reads in thousands of pounds per square inch, is always included and indicates the pressure within the cylinder and the connecting plumbing. A lower scale which reads in thousands of pounds of force, can be overlaid on the the gauge face if the cylinder size is known. These gauge face overlays are available from Navtec at no charge. Please specify cylinder size when ordering. The pressure within the system can be converted to actual force exerted by the cylinder using Table IV or the formula below:



$$\text{Pressure (lbs/Inch}^2\text{)} \times \text{Cylinder area (Inch}^2\text{)} = \text{Force (lbs)}$$

Gauges have a backing card that is specially treated to provide night illumination. If backing card does not provide enough light, recharge by passing a flashlight beam slowly over the gauge.

**TABLE III  
CYLINDER FORCE vs. PRESSURE**

CYL/VANG	ROD DIAM		CYL. AREA		OBSERVED PRESSURE (from gauge, in psi)						
	SIZE	(In)	(mm)	(In <sup>2</sup> )	(cm <sup>2</sup> )	1000		3000		5000	
					(lbs)	(kg)	(lbs)	(kg)	(lbs)	(kg)	
-6 cyl.	0.437	11.1	0.639	4.12	640	290	1920	870	3190	1450	
-6 vang	0.625	15.9	0.482	3.11	480	220	1450	656	2410	1090	
-10 cyl.	0.500	12.7	1.160	7.48	1180	530	3480	1580	5800	2630	
-10 vang	0.750	19.1	0.914	5.89	910	410	2740	1240	4570	2070	
-12 cyl.	0.625	15.9	1.525	9.63	1525	690	4580	2080	7620	3460	
-12 vang	0.875	22.2	1.280	7.93	1230	560	3690	1670	6150	2790	
-17 cyl.	0.625	15.9	2.173	14.02	2170	990	6520	2960	10860	4930	
-17 vang	1.000	25.4	1.695	10.93	1690	770	5080	2300	8470	3840	
-22 cyl.	0.750	19.1	2.785	17.96	2780	1260	8350	3306	13920	6310	
-22 vang	1.000	25.4	2.442	15.75	2440	1110	7330	3320	12210	5540	
-30 cyl.	0.875	22.2	4.414	28.47	4410	2000	13240	6000	22070	10000	
-30 vang	1.250	31.8	3.778	24.37	3780	1710	11330	5140	18890	8570	
-40 cyl.	1.000	25.4	6.435	41.51	6430	2920	19300	8750	32170	14580	
-40 vang	1.250	31.8	5.993	38.66	5990	2720	17980	8150	29960	13590	
-60 cyl.	1.250	31.8	8.571	55.30	8570	3890	25710	11660	42850	19430	
-60 vang	1.500	38.1	8.031	51.81	8030	3640	24090	10930	40150	18210	
-90 cyl.	1.250	31.8	11.541	74.46	11540	5230	34620	15700	57700	26170	
-90 vang	1.875	47.6	10.007	64.56	10000	4540	30020	13610	50030	22690	
-110 cyl.	1.375	34.9	14.646	94.49	14650	6640	43940	19930	73230	33210	
-110 vang	2.125	54.0	12.585	81.19	12580	5710	37750	17120	62920	28540	
-150 cyl.	1.500	38.1	18.120	116.91	18130	8220	54360	24650	90600	41090	
-150 vang	2.375	60.3	15.729	99.72	15460	7010	46370	21030	77280	35050	

## NAVTEC LIMITED WARRANTY

- WARRANTY:** Navtec warrants its products, in normal usage, to be free of defects in materials and workmanship for a period of one year from date of original purchase by the user, subject to the conditions and limitations below. Any part that proves to be defective in normal usage during that one year period will be repaired or replaced Navtec. This warranty is subject to the following conditions and limitations:
  - Navtec's liability shall be limited to repair or replacement (choice of remedy at Navtec's option) of goods or parts defective in materials or workmanship. This shall be the buyer's exclusive remedy in contract, tort or otherwise.
  - Except as otherwise provided, quality shall be in accordance with Navtec's specifications.
  - Determination of the suitability of the material for the use contemplated by the buyer is the sole responsibility of the buyer, and Navtec shall have no responsibility in connection with such suitability.
  - Navtec shall not be liable for any harm resulting from: (1) failures due to use of products in applications for which they are not intended. (2) failures due to corrosion, wear and tear, or improper installation. In the case of rod rigging products, improper installation includes, but is not limited to, the use of rod rigging end fittings other than those manufactured by Navtec or meeting Navtec specifications. Improper installation also includes, but is not limited to, the use of dies other than those leased by Navtec to Authorized Navtec Representatives, to form the head which is part of the patented Navtec Headed Rod Rigging System.
  - Navtec shall not be responsible for shipping charges or installation labor associated with any warranty claims.
  - Service by anyone other than Authorized Navtec Representatives shall void this warranty unless in accordance with Navtec guidelines and standards of workmanship.
- DISCLAIMER OF IMPLIED WARRANTIES.** There are no warranties of merchantability, fitness for purpose, or any other kind, express or implied, and none shall be implied by law. The duration of any such warranties that are nonetheless implied by law for the benefit of a consumer shall be limited to a period of one year from original purchase by the user. Some states do not allow limitations on how long an implied warranty lasts so the above limitations may not apply to you.
- LIMITATIONS OF CONSEQUENTIAL DAMAGES.** Navtec shall not be liable for consequential damages to yachts, equipment or other property, or persons due to any failure of Navtec equipment. Some states do not allow the exclusion or limitation of incidental or consequential damages, so the above limitation or inclusion may not apply to you.
- This warranty gives you specific legal rights and you may also have other rights which vary from state to state.

New Whitfield Street, P.O. Box 388, Guilford, CT. 06437-0388 USA  
Tel: (203) 458 3163 Fax: (203) 458 9291

# NAVTEC®